

Hydroprocessing upgrades to meet changing fuels requirements

Adapting installed hydroprocessing units through a variety of schemes enables refiners to shift their fuels slates to meet changing demand and specifications

JAY PAREKH and HARJEET VIRDI
Chevron Lummus Global

The current economic environment has imposed a reduction on capital expenditure budgets for new expansions, along with some erosion in demand for fuel products, which is squeezing refinery margins. However, refiners are still facing challenges to meet stringent clean fuels regulations and maintain requirements for product quality.

Refiners have to think creatively in order to meet specifications and develop projects that are profitable, with returns on investment that are subject to a higher level of scrutiny in view of restrictions on capex. Light-heavy crude differentials have recently eroded, but the expectation is that the differentials will recover and encourage the development of projects that meet fuels regulations with some bottom of the barrel conversion to light products. There also appears to be momentum in the marketplace to increase diesel production, in the US in particular, with an expected increase in the use of diesel-powered engines for personal vehicles. Revamps of existing units can provide the refiner with the ability to generate high returns on restricted capital investments.

Chevron invented the modern hydrocracking process in 1959. In recent decades, Chevron Lummus Global (CLG) has debottlenecked and revamped a number of existing hydroprocessing units to meet changes in fuels regulations and feedstocks, achieve capacity increases and increase the output of light products. This article discusses four revamp configurations in all areas of hydroprocessing technology, some of which have been fully implemented

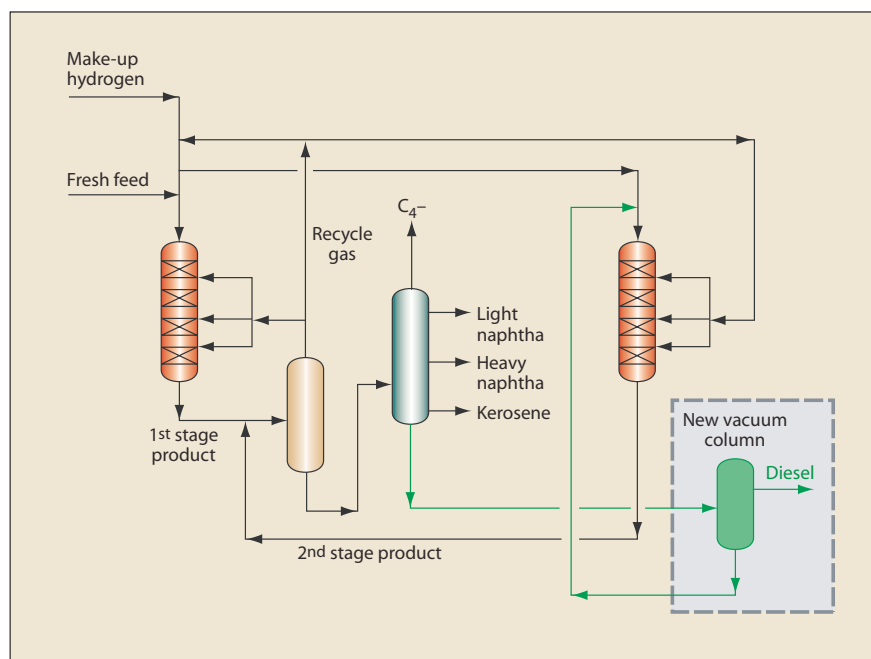

Figure 1 Two-stage recycle (TSR) with vacuum column for diesel recovery

and others that are at various stages of project execution.

Conversion from gasoline/jet to diesel

An Isocracking licensee operating a two-stage with recycle (TSR) configuration hydrocracker with intermediate distillation commissioned a revamp to expand unit capacity and shift the mode of operation from naphtha production to a distillate-selective operation. The objective of the revamp is to increase the nominal feed rate to the unit by 20% and to increase the diesel yield from zero to more than 40% (with a decrease in naphtha and jet yields).

The inherent advantage of a hydrocracker is the ability to shift the yield selectivity of the operation with a shift in the recycle cut point (RCP), which is defined as the cut point between the heaviest product and the

unconverted oil. By increasing the recycle cut point, more distillate products can be recovered in the intermediate distillation section and less unconverted oil is sent to the second stage for further conversion. The end result is less workload on the catalyst and a reduction in chemical hydrogen consumption, with less overall cracking to naphtha as well as a reduction in light ends make. This enables a refiner to increase feed rates while maintaining catalyst life, without having to debottleneck the gas recovery section of the plant. It results in a reduction in hydrogen demand, which fosters straightforward debottlenecking to achieve higher throughput.

Since the unit was originally designed to co-produce naphtha and jet, a revamp to introduce diesel selectivity requires modifications to

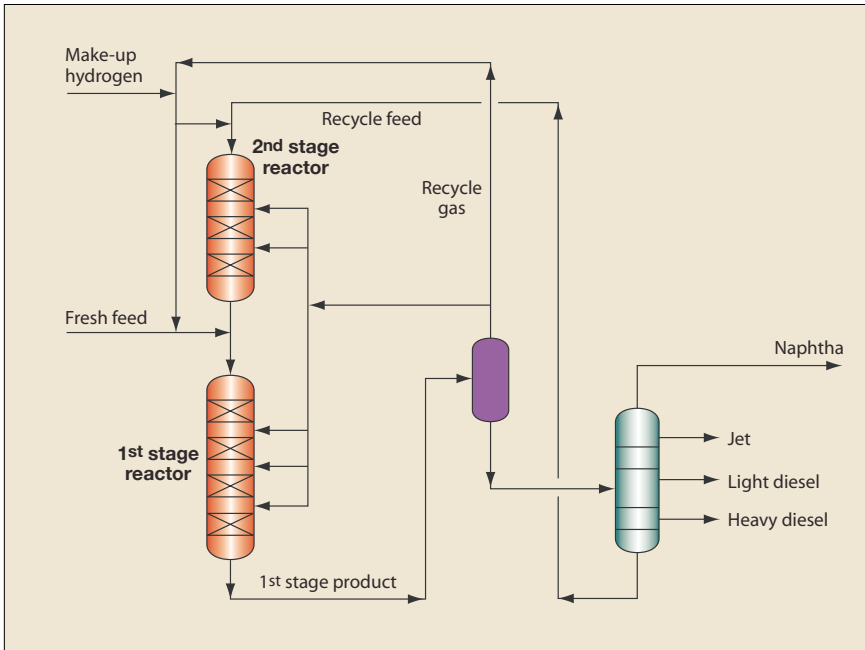

Figure 2 SRS Isocracking

the existing fractionator in order to “lift” the level of diesel product. However, the ability to add another product draw is limited by the size of the column and the available reboiler duty. Therefore, an additional vacuum column will be added downstream of the fractionator to pull diesel product to a 350°C cut point. An additional heater is not required. Figure 1 shows a schematic of the TSR unit with the addition of the vacuum column. The remainder of the unit’s debottleneck involves modification of the recycle compressor, feed pumps and other minor capital expenditures on the heat exchange train. This revamp project is currently in detail engineering, with an expected startup date in 2012.

Two-stage hydrocracker revamp

A licensee originally commissioned in the mid-1990s a TSR unit with selectivity towards middle distillates. The refiner was evaluating a project to increase unit capacity and extend run length significantly. A traditional revamp would necessitate additional reactor volume and modifications to the recycle gas compressor. However, a novel solution, using a process recently commercialised by CLG called single-stage reverse sequencing (SSRS), would enable the company to achieve its goals with substantially less capital expenditure.

A schematic of the SSRS flow scheme is shown in Figure 2. Like a TSR unit, the SSRS also takes advantage of a

clean second-stage environment, with overall rate constants much greater than the rate constants from the first stage. This second-stage environment permits full conversion of difficult feeds, with less than half the reactor volume needed compared to a single-stage once-through (SSOT) or single-stage recycle (SSREC). The obvious difference between the traditional TSR configuration and the SSRS configuration is that the effluent from the second stage flows directly to the inlet of the first stage, which provides the following benefits over a conventional TSR configuration:

- Effluent from the second stage provides a heat sink for the first stage, reducing demand for first-stage quench gas by up to 40%
- Excess hydrogen from the second stage is used to supplement the gas-to-oil requirement for the first stage
- The overall recycle gas compressor load is reduced typically by up to 70%
- Only one reactor furnace is required.

SSRS revamp

The economics of a high-pressure hydroprocessing revamp are largely influenced by the recycle gas compressor costs. The SSRS flow scheme imposes a small incremental load on the recycle gas compressor. This is fairly intuitive for the consideration of a SSOT or SSREC revamp of a two-stage unit, but less intuitive for a TSR revamp. CLG recommended this solution for the refiner, and the scheme is shown in Figure 3. In the TSR configuration, a guard bed is added to the first stage, and an additional first-stage reactor is added between the second-stage effluent and the product fractionator. The guard bed was added to increase demetallation and the overall volume of the first-stage reactor to extend the length of the catalyst run. The unit (pre-revamp) is currently running at 133% of original design capacity. The addition of two new reactors will enable the refiner to increase the unit’s throughput by another 42%, for a total of 175% of original design. The revamp will also extend the run length by 30%. This will provide for a 228%

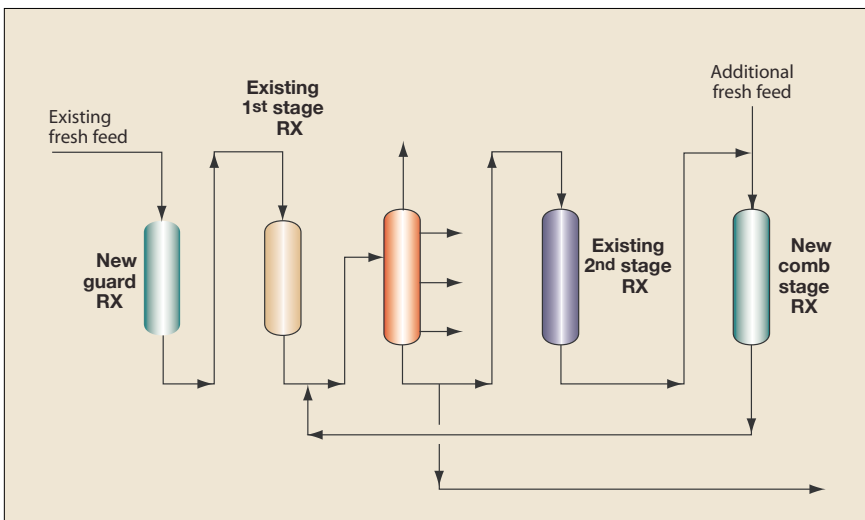

Figure 3 Revamp configuration using reverse staging

increase in processed barrels per catalyst fill, compared to the original design, and will all be achieved using the existing recycle gas compressor.

This project was scheduled to start up in Q4 2009. The unit will continue to run in a maximum mid-distillate mode.

Hydrocracking for lubes and integrated fuels and lubes production

The benefits of hydrocracking to produce feeds for lubricant base stocks — as well as other downstream process operations such as FCCs and ethylene plants — are well known and in use in plants around the world. In

fuels, can also provide a flexible platform for producing a range of lube base oils. The patented principle is shown in Figure 4, where the configuration can be set up to produce three lube base oil feedstocks, while maintaining to a large degree the predetermined overall conversion level for fuels. Each of the three lubricating oil streams is of different quality and boiling range. Investment to recover each stream for further Isodewaxing/Isosfinishing steps can even be phased to match market requirements. Bharat Petroleum Corporation (BPCL), a refiner in India, recognised the potential of the TSR-

eliminated for the lubes hydro-processing unit. BPCL's lubes plant successfully started up one year following feed into the hydrocracker in 2006.

Residue upgrading

The need to process resid feeds with a high metal content, to run high severity operations in resid desulphurisation (RDS) units, or to extend cycle length and throughput via retrofits to plants already constructed, led to the idea of replacing the catalyst while the unit is on-stream. Liquid-filled upflow reactor (UFR) technology with on-stream catalyst replacement (OCR) involves the catalyst moving in countercurrent flow to a mix of residuum and hydrogen, to ensure full use of the catalyst. In operation, the most deactivated catalyst encounters the most reactive feed at the reactor's (bottom) inlet, and spent catalyst is withdrawn from the bottom. The least reactive feed contacts the most active (fresh) catalyst at the reactor's (top) exit. Fresh catalyst is introduced at the top during the on-stream catalyst replacement cycle. OCR technology is being commercially demonstrated in four units currently in operation.

As the need arose to extract most of the value provided by the OCR's upflow reactor, while minimising capital investment and avoiding catalyst-handling facilities, the idea of the UFR emerged. While it cannot provide all of the demetallation to be expected of an OCR, the UFR is able to add utility in other ways. Since it is not a moving bed design, multiple beds of different catalysts can be used, including combinations of HDM and HDS catalysts (Figure 5). The major attribute of the UFR (as well as the OCR) is its very low pressure drop. This avoids typical limitations in the recycle compressor and, therefore, revamping an existing vacuum resid desulphurisation (VRDS) unit is feasible and economically attractive. This was one of the main reasons why the ENI Taranto Refinery in Italy selected UFR technology.

ENI Taranto's residue hydro-conversion unit was revamped to expand the unit's capacity by 25%.

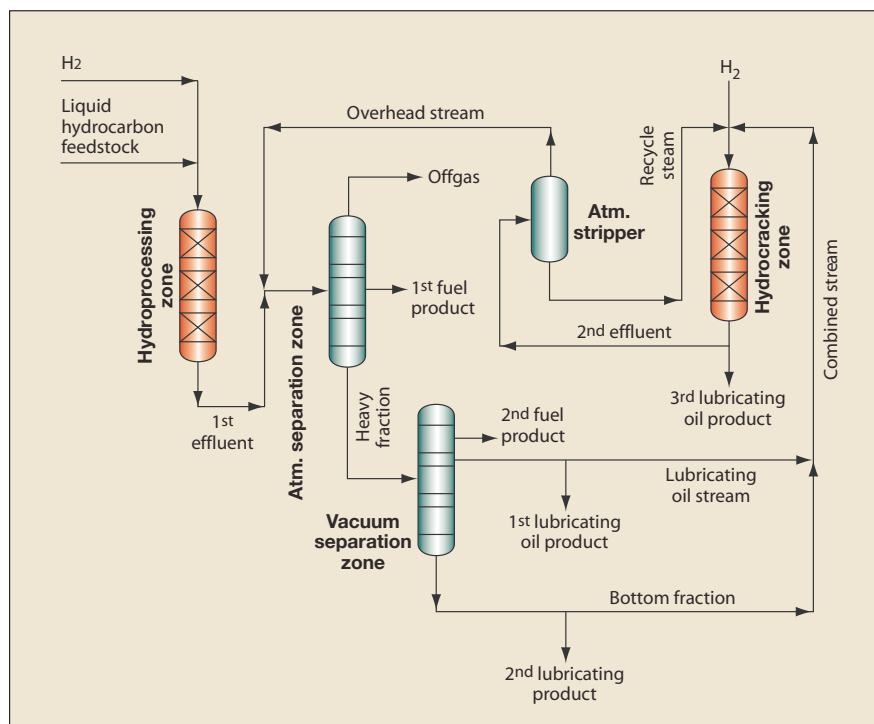

Figure 4 Isocracking for fuels and lubes

most of these cases, there is a dedicated lube hydrocracker, followed by dewaxing and finishing steps. What is more unusual is the integration of a hydrocracker, primarily devoted to making high-quality fuels (especially ultra-low sulphur, low-aromatic diesel), while also producing excellent feed for a dewaxing/finishing unit. The benefits of such an approach are clear: a lower capital investment than is required to build separate fuels and lubes hydrocrackers; and a lower cost of producing high-value lube base stocks.

This TSR configuration, with its innate advantages for making clean

configured hydrocracker. With CLG's TSR process, BPCL designed an integrated Isodewaxing/Isosfinishing unit, using the flexibility available in its TSR to supply its forecast lube base oil market.

The company constructed the unit with minimal interruption to the imminent startup of the hydrocracker. Phasing in the design of the Isodewaxing/Isosfinishing unit with the hydrocracker project before all of the major equipment had been ordered enabled BPCL and CLG to reduce costs by over 30%, compared to a standalone unit. Several major pieces of high-pressure equipment could be

Startup was in 2006. In addition to increased throughput, it has provided the refiner with the ability to process heavier local crudes such as Tempa Rossa and Belaym.

Conclusions

In order to provide refiners with opportunities to revamp hydroprocessing units at lower levels of total capital investment, CLG has developed and commercialised a number of process concepts to make the most of existing hardware. This is accomplished by making optimum use of the existing unit's design and by integration of what were previously thought of as separate hydroprocessing plants. All concepts discussed in this article have been designed for commercial units, two of which are currently operating and the other units will start up within the next few years.

Isocracking, Isodewaxing, Isofinishing, OCR and UFR are marks of Chevron Lummus Global.

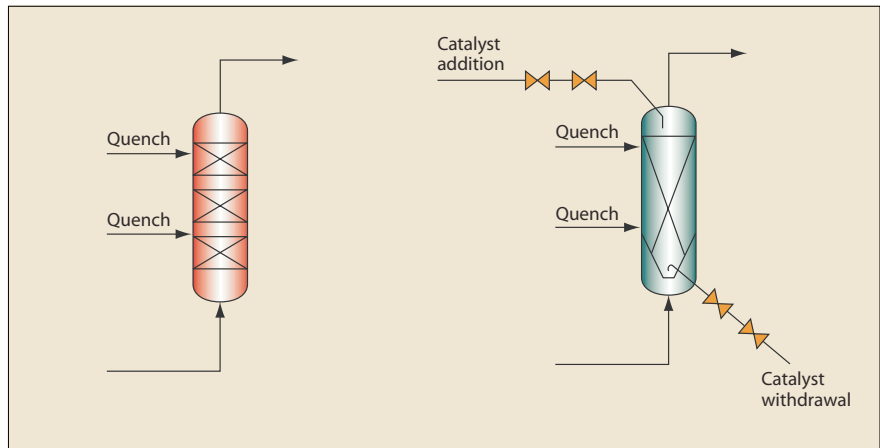

Figure 5 UFR vs OCR reactors

References

- 1 Wade R, Vislocky J, Maesen T, Torchia D, Hydrocracking Catalyst developments and innovative processing scheme, NPRA Annual Meeting, Mar 2009.
- 2 Spieler S, Mukherjee U, Dahlberg A, Upgrading residuum to finished products in integrated hydroprocessing platforms — solutions and challenges, NPRA Annual Meeting, Mar 2006.
- 3 Steegstra J, Louie W S, Mukherjee U, Innovative and cost effective designs to achieve multiple clean fuels

solutions, BBTC 2004 Antwerp, Oct 2004.

Jay Parekh is Process Engineering Team Leader for Chevron Lummus Global, Richmond, California. He has worked for Chevron for 18 years, with over ten years in the hydroprocessing and refining industry. *Email: Jay.Parekh@chevron.com*

Harjeet Viridi is Hydrocracking Technology Manager for Chevron Lummus Global, Richmond, California. He has worked in the hydroprocessing and refining industry for 28 years. *Email: Harjeet.Viridi@chevron.com*